

- ▶ standard design
- ▶ short design
- ▶ preferential series
- ▶ top-series

standard, short, preferential, top

dimensions
 Ø3mm
 M4 x 0.5
 Ø4mm
 M5 x 0.5
 Ø6.5mm
 M8 x 1
 M12 x 1
 M18 x 1
 M30 x 1.5

flush switching distance **0.6 to 15mm**
 non-flush switching distance **2.0 to 15mm**

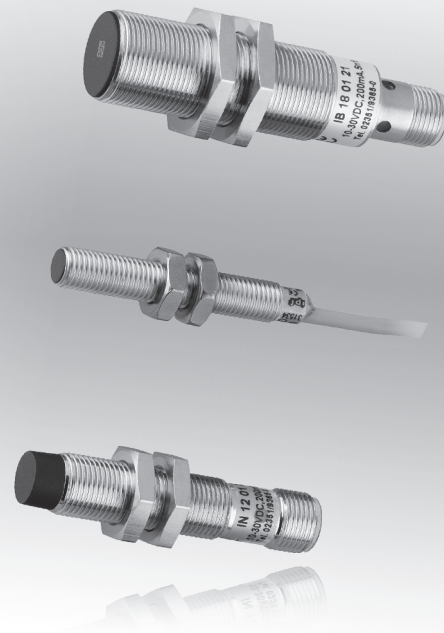

- ✓ LED display of the switching signal
- ✓ robust metal housing
- ✓ different lengths
- ✓ connection via cable, M8-, M12- or microchange-connector (MC)

manifold output signals and connection possibilities

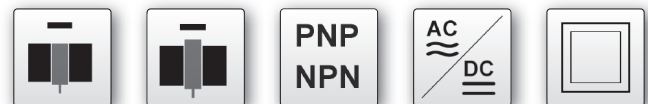

description

An important feature of these sensors is the cast electronics in a stable, metal housing. As a consequence of the compound, the electronics are perfectly protected from vibrations. As such, the devices are also sealed against fluids, except for the connector side.

They are much more resistant to mechanical stress than conventional proximity switches made from plastic.

The ambient temperature can be up to +70°C. In addition, these sensors work through the contactless detection of the object, without wear and tear.

Due to the large number of mechanical dimensions, the devices can be exchanged against many other proximity switches without any problems.

The range of applications in which these inductive sensors can be used extends, for example, from machine/systems engineering, automotive industry, conveyor technology and packaging industry, technology for the printing/paper industries, chemical engineering and process engineering (as well as many others).

An inductive sensor (proximity switch, position sensor, initiator) is a contactless switch which reliably detects metallic objects. In the case of inductive sensors, a correc-

tion factor is stated which evaluates the reduction of the switching distance in relation to the different materials that the object is made from. This factor depends on the type, characteristics (internal structure), size and geometry of the material that the object to be detected is made from. The stated switching distance value relates to steel St37 (factor 1 steel). In order to assess the approximate switching distance for materials which differ from this, the value has to be multiplied by the appropriate correction factor.

For realizing the maximum switching distance, the size and characteristics of the object to be detected (standard target and/or flat surface) should be taken into account.

application examples

- ▶ integration in machine parts in the automation technology
- ▶ checking the presence of metal parts with various dimensions
- ▶ detecting object heights, e.g. metal parts on conveyor belts
- ▶ detection of objects through the walls of non-metallic containers and tubes

Notes on inductive proximity switches

I	inductive sensor
IA	flush, preferential series
IB	flush, standard and short design, top-series
IM	non-flush, preferential series
IN	non-flush, standard and short design, top-series

functional principle

The oscillation coil behind the active surface of the proximity switch produces an alternating electromagnetic field. Any electrically conductive material entering the field will induce rotational currents extracting energy from the oscillating circuit. The damping of the oscillator is then converted into a switching signal in the output amplifier.

It follows the functional principle that all metals are detected, moving or not. Important: The high frequency field produces no measurable increase in temperature and no magnetic influence inside the object to be detected. That means the sensors operate without interacting with the system.

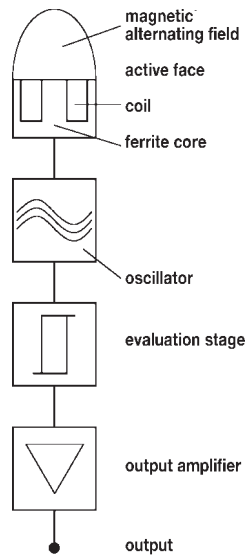

functional principle of an inductive proximity switch

switching distance / norm measuring plate

The distance to the sensor surface, where a metal causes a change in the switching state, is called switching distance. This distance is not the same for all metals. That is why a so-called correction factor has been specified for the respective metal, e.g. copper or aluminum. The nominal switching distance S_n is determined by a norm measuring plate. This is a quadratic metal plate made from steel (St37) with a thickness of 1mm and a smoothed surface. The edge length is $3 \times S_n$ if $3 \times S_n$ is larger than the diameter of the active surface, otherwise the edge length is the same as the diameter of the active surface.

One differentiates between the normal switching distance S_n , which is determined without consideration for manufacturing tolerances or external influences, and the operational switching distance S_a .

The safe operational switching distance is between 0 and 81% of S_n ($0 < S_a < 0.81 \times S_n$).

switching hysteresis

During the approach and subsequent removal of the measuring plate from the initiator there will be a difference between switch-on point and switch-off point. This integrated hysteresis prevents the switching output from oscillating during mechanical vibrations. Usually the hysteresis is between 5 to 15% of S_n .

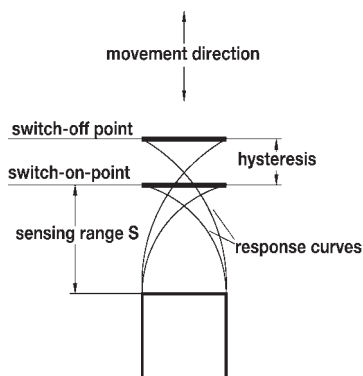

output circuit

For the switching outputs of direct current devices a differentiation is made between PNP and NPN. For PNP outputs the load is connected in such a way that it is energized (positive switching) when the sensor is driven to full output (damping). NPN devices maintain their load permanently energized, switching the earth connection only (negative switching). A corresponding wiring diagram is supplied with every sensor.

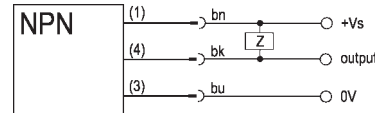
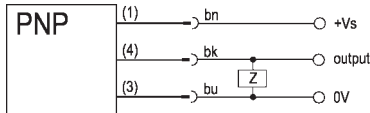

For devices with M12-connector and normally closed contact function (nc), the switching output is wired via PIN2. For this reason a 4-wire cable socket should be used and the connection made via the white wire.

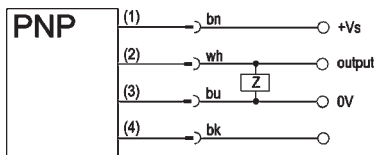

The alternating current devices are usually 2-wire devices without short-circuit protection. Consequently a load must be connected, which allows for a minimum load current of 2mA, however, not exceeding the maximum load current.

Proximity switches with analog output circuits are used in the control and measurement industry. These devices produce either a linear voltage (0 ... 10V) or a current (4 ... 20mA) instead of a switching signal.

series connection

When a number of sensors are connected in series, the voltage drop of each device should be taken into account in order to ensure that the final device also receives the required operating voltage. The internal electronics permits a maximum of 3 devices to be connected in series.

To be operationally safe the connection in series of 3-wire PNP sensors requires a logical AND-gate, e.g. VL250100.

parallel connection

When connecting 3-wire PNP-sensors in parallel, the internal resistance of the sensor that is driven to full output influences the other proximity switches. This requires decoupling diodes to be inserted into the outputs. A logical OR-gate, e.g. the VL250120, can be used to facilitate the connection in parallel.

mounting

Please follow the mounting instructions for flush or non-flush sensors when installing inductive proximity switches into a metal backing material to avoid undefined switching of the device. For a flush device the active face may be on one level with the backing material.

Non-flush sensors must protrude. As a rule of thumb use 2x the nominal switching distance of the sensor.

mounting instructions for flush sensors

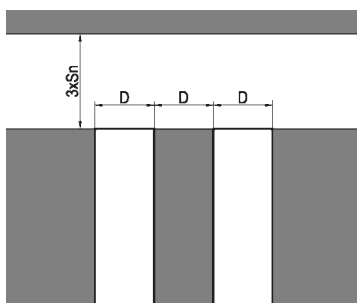

mounting instructions for non-flush sensors

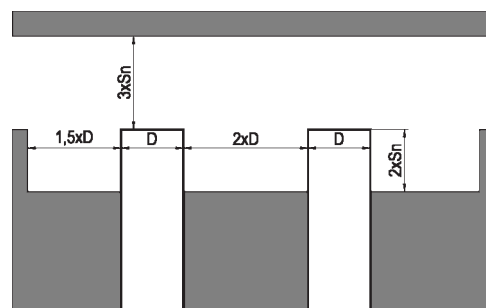

switching frequency

The switching frequency states the maximum number of available switching operations per second. Every switching operation of the inductive proximity switch triggers the oscillating circuit.

The time needed for the oscillation puts a limit on the switching frequency.

For half the nominal switching distance the pulse to pause ratio should be at least 1 : 2,

i.e. when choosing the right proximity switch, a compromise needs to be made between the size of the sensor and the switching frequency. General rule: The larger the sensor, the smaller the switching frequency.

tightening torques

To avoid damage when mounting proximity switches, never exceed the tightening torque given.

stainless steel thread

M5 = 2Nm

M8 = 10Nm

M12 = 20Nm

M18 = 55Nm

nickel-plated brass thread

M8 = 7Nm

M12 = 15Nm

M18 = 40Nm

M30 = 200Nm

plastic thread

M12 = 1.5Nm

M18 = 3Nm

M30 = 5Nm

active switching zone / active surface:

The active switching zone is the area in front of the active surface, within which the proximity switch reacts to the approach of metal parts, i.e. changes the state of the output.

nominal switching distance (S_n):

The distance at which a metal part that is approaching the active surface of the proximity switch causes a change in the state of the switching output.

repeatability:

Repeat accuracy of two measurements under standardized conditions. The difference in the measured values should be less than 10%.

output function:

Normally open: object within the area of the active switching zone – output switched

Normally closed: object within the area of the active switching zone – output inhibited

readiness delay:

Time required by the proximity switch to be functional after the supply voltage is applied (lies in the millisecond range).

correction factor:

Specify the reduction in the switching distance, if materials other than steel St37 are used. The change in the switching distance depends on the type, characteristics (internal structure), size and the geometry of the material that is to be detected.

typical correction factors: St37: 1 V2A: approx. 0.7 Ms: approx. 0.4 Al: approx. 0.3 Cu: approx. 0.2

In order to assess the approximate switching distance on the materials which differ from St37, the switching distance for St37 has to be multiplied by the appropriate correction factor.

repeat accuracy

The repeat accuracy (according to IEC 60947-5-2 / EN 60947-5-2) is the repeat accuracy of the real switching distance S_r over a period of 8 hours at an ambient temperature of (23 ± 5)°C and a defined operating voltage V_s. The specified repeat accuracy corresponds to this definition. Generally the repeat accuracy is considerably better in case of sequent measurements.

reverse polarity protection:

An internal protection prevents destruction of the proximity switch if the connection lines are accidentally swapped.

short-circuit protection:

An internal protection prevents destruction of the proximity switch in case of an overcurrent.

switching point drift:

The switching point shifts due to the change in ambient temperature.

Warning: Never use these devices in applications where the safety of a person depends on their functionality.

	short design	short design	short design	short design
article-no.	IBR30104	IBR30174	IB040104	IB040174
switching distance (Sn)	0.6mm	0.6mm	0.6mm	0.6mm
output signal	pnp, no	pnp, no	pnp, no	pnp, no
mounting	flush	flush	flush	flush
connection	cable	M8-cable connector	cable	M8-cable connector
article-no.	IBR30204	*	IB040204	*
output signal	pnp, nc	pnp, nc	pnp, nc	pnp, nc
article-no.	*	*	*	*
output signal	npn, no	npn, no	npn, no	npn, no
article-no.	*	*	*	*
output signal	npn, nc	npn, nc	npn, nc	npn, nc
* on request				
TECHNICAL DATA				
switching distance (Sn)	0.6mm	0.6mm	0.6mm	0.6mm
output signal	see above	see above	see above	see above
operating voltage	10 ... 30V DC	10 ... 30V DC	10 ... 30V DC	10 ... 30V DC
current consumption (w/o load)	† 5.5mA	† 5.5mA	† 5.5mA	† 5.5mA
output current (max. load)	100mA	100mA	100mA	100mA
voltage drop (max. load)	1.5V DC	1.5V DC	1.5V DC	1.5V DC
Norm measuring plate	acc. to EN 60947-5-2	acc. to EN 60947-5-2	acc. to EN 60947-5-2	acc. to EN 60947-5-2
hysteresis	< 15%	< 15%	< 15%	< 15%
repeat accuracy	acc. to EN 60947-5-2	acc. to EN 60947-5-2	acc. to EN 60947-5-2	acc. to EN 60947-5-2
correction factor	see page 5	see page 5	see page 5	see page 5
switching frequency	5kHz	5kHz	5kHz	5kHz
display (signal)	yellow LED	yellow LED	yellow LED	yellow LED
short-circuit protection	+	+	+	+
reverse polarity protection	+	+	+	+
dimensions	Ø 3mm	Ø 3mm	M4x0.5	M4x0.5
length (thread/complete)	-/22mm	-/22mm	19mm/22mm	19mm/22mm
housing material	stainl. steel	stainl. steel	stainl. steel	stainl. steel
operating temperature	-25 ... +70°C	-25 ... +70°C	-25 ... +70°C	-25 ... +70°C
degree of protection (EN 60529)	IP67	IP67	IP67	IP67
connection	2m PUR cable, 3-wire	M8-cable connector, 3-pin	2m PUR cable, 3-wire	M8-cable connector, 3-pin
connection accessories	-	e.g. VK200075	-	e.g. VK200075
mounting accessories (clip)	-	-	AY000044	AY000044

	short design	short design	short design	short design
article-no.	IBR40104	IBR40174	IB050104	IB050174
switching distance (Sn)	0.8mm	0.8mm	0.8mm	0.8mm
output signal	pnp, no	pnp, no	pnp, no	pnp, no
mounting	flush	flush	flush	flush
connection	cable	M8-connector	cable	M8-connector
article-no.	IBR40204	IBR40274	IB050204	IB050274
output signal	pnp, nc	pnp, nc	pnp, nc	pnp, nc
article-no.	IBR41104	*	IB051104	IB051174
output signal	npn, no	npn, no	npn, no	npn, no
article-no.	*	*	*	*
output signal	npn, nc	npn, nc	npn, nc	npn, nc

* on request

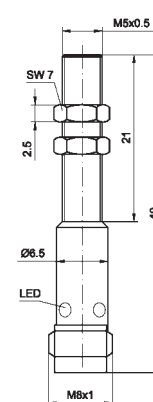
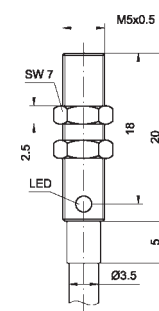
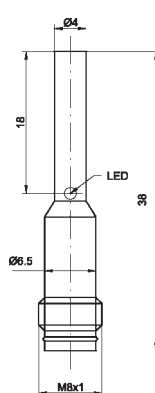
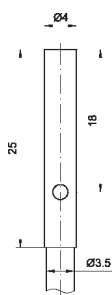

TECHNICAL DATA

switching distance (Sn)	0.8mm	0.8mm	0.8mm	0.8mm
output signal	see above	see above	see above	see above
operating voltage	10 ... 30V DC	10 ... 30V DC	10 ... 30V DC	10 ... 30V DC
current consumption (w/o load)	ffi 5.5mA	ffi 5.5mA	ffi 5.5mA	ffi 5.5mA
output current (max. load)	200mA	200mA	200mA	200mA
voltage drop (max. load)	1.5V DC	1.5V DC	1.5V DC	1.5V DC
Norm measuring plate	acc. to EN 60947-5-2	acc. to EN 60947-5-2	acc. to EN 60947-5-2	acc. to EN 60947-5-2
hysteresis	< 15%	< 15%	< 15%	< 15%
repeat accuracy	acc. to EN 60947-5-2	acc. to EN 60947-5-2	acc. to EN 60947-5-2	acc. to EN 60947-5-2
correction factor	see page 5	see page 5	see page 5	see page 5
switching frequency	5kHz	5kHz	5kHz	5kHz
display (signal)	yellow LED	yellow LED	yellow LED	yellow LED
short-circuit protection	+	+	+	+
reverse polarity protection	+	+	+	+
dimensions	Ø 4mm	Ø 4mm	M5x0.5	M5x0.5
length (thread/complete)	-/25mm	-/38mm	18mm/25mm	23mm/38mm
housing material	stainl. steel	stainl. steel	stainl. steel	stainl. steel
operating temperature	-25 ... +70°C	-25 ... +70°C	-25 ... +70°C	-25 ... +70°C
degree of protection (EN 60529)	IP67	IP67	IP67	IP67
connection	2m PUR cable, 3-wire	M8-connector, 3-pin	2m PUR cable, 3-wire	M8-connector, 3-pin
connection accessories	-	e.g. VK200075	-	e.g. VK200075
mounting accessories (universal holder)	-	-	AY000115	AY000115
mounting accessories (clip)	AY000044	AY000044	AY000045	AY000045

	preferential series	preferential series	standard design	short design
article-no.	IA060100	IA060170	IB060100	IB060104
switching distance (Sn)	1.5mm	1.5mm	1.5mm	1.5mm
output signal	pnnp, no	pnnp, no	pnnp, no	pnnp, no
mounting	flush	flush	flush	flush
connection	cable	M8-connector	cable	cable
article-no.	-	-	IB060200	IB060204
output signal	pnnp, nc	pnnp, nc	pnnp, nc	pnnp, nc
article-no.	-	-	IB061100	IB061104
output signal	nnpn, no	nnpn, no	nnpn, no	nnpn, no
article-no.	-	-	*	*
output signal	nnpn, nc	nnpn, nc	nnpn, nc	nnpn, nc
* on request				
TECHNICAL DATA				
switching distance (Sn)	1.5mm	1.5mm	1.5mm	1.5mm
output signal	see above	see above	see above	see above
operating voltage	10 ... 30V DC	10 ... 30V DC	10 ... 30V DC	10 ... 30V DC
current consumption (w/o load)	† 15mA	† 15mA	† 15mA	† 15mA
output current (max. load)	200mA	200mA	200mA	200mA
voltage drop (max. load)	2.0V DC	2.0V DC	2.0V DC	2.0V DC
Norm measuring plate	acc. to EN 60947-5-2	acc. to EN 60947-5-2	acc. to EN 60947-5-2	acc. to EN 60947-5-2
hysteresis	< 15%	< 15%	< 15%	< 15%
repeat accuracy	acc. to EN 60947-5-2	acc. to EN 60947-5-2	acc. to EN 60947-5-2	acc. to EN 60947-5-2
correction factor	see page 5	see page 5	see page 5	see page 5
switching frequency	1kHz	1kHz	1kHz	1kHz
display (signal)	yellow LED	yellow LED	yellow LED	yellow LED
short-circuit protection	+	+	+	+
reverse polarity protection	+	+	+	+
dimensions	Ø 6.5mm	Ø 6.5mm	Ø 6.5mm	Ø 6.5mm
length (thread/complete)	-/40mm	-/50mm	-/50mm	-/35mm
housing material	nickel-plated brass	nickel-plated brass	stainl. steel	stainl. steel
operating temperature	-25 ... +70°C	-25 ... +70°C	-25 ... +70°C	-25 ... +70°C
degree of protection (EN 60529)	IP67	IP67	IP67	IP67
connection	2m PUR cable, 3-wire	M8-connector, 3-pin	2m PUR cable, 3-wire	2m PUR cable, 3-wire
connection accessories	-	e.g. VK200075	-	-
mounting accessories (clip)	AY000046	AY000046	AY000046	AY000046

	standard design	short design	short design	short design
article-no.	IB060170	IB060174	IB060185	IB0601A4
switching distance (Sn)	1.5mm	1.5mm	1.5mm	1.5mm
output signal	pnp, no	pnp, no	pnp, no	pnp, no
mounting	flush	flush	flush	flush
connection	M8-connector	M8-connector	M8-connector	cable
article-no.	IB060270	IB060274	IB060285	IB0602A4
output signal	pnp, nc	pnp, nc	pnp, nc	pnp, nc
article-no.	IB061170	IB061174	*	IB0611A4
output signal	npn, no	npn, no	npn, no	npn, no
article-no.	*	*	*	*
output signal	npn, nc	npn, nc	npn, nc	npn, nc
* on request				
TECHNICAL DATA				
switching distance (Sn)	1.5mm	1.5mm	1.5mm	1.5mm
output signal	see above	see above	see above	see above
operating voltage	10 ... 30V DC	10 ... 30V DC	10 ... 30V DC	10 ... 30V DC
current consumption (w/o load)	† 15mA	† 15mA	† 15mA	† 15mA
output current (max. load)	200mA	200mA	200mA	200mA
voltage drop (max. load)	2.0V DC	2.0V DC	2.0V DC	2.0V DC
Norm measuring plate	acc. to EN 60947-5-2	acc. to EN 60947-5-2	acc. to EN 60947-5-2	acc. to EN 60947-5-2
hysteresis	< 15%	< 15%	< 15%	< 15%
repeat accuracy	acc. to EN 60947-5-2	acc. to EN 60947-5-2	acc. to EN 60947-5-2	acc. to EN 60947-5-2
correction factor	see page 5	see page 5	see page 5	see page 5
switching frequency	1kHz	1kHz	1kHz	5kHz
display (signal)	yellow LED	yellow LED	yellow LED	yellow LED
short-circuit protection	+	+	+	+
reverse polarity protection	+	+	+	+
dimensions	Ø 6.5mm	Ø 6.5mm	Ø 6.5mm	Ø 6.5mm
length (thread/complete)	-/60mm	-/45mm	-/29mm	-/16mm
housing material	stainl. steel	stainl. steel	stainl. steel	stainl. steel
operating temperature	-25 ... +70°C	-25 ... +70°C	-25 ... +70°C	-25 ... +70°C
degree of protection (EN 60529)	IP67	IP67	IP67	IP67
connection	M8-connector, 3-pin	M8-connector, 3-pin	M8-connector, 3-pin	2m PUR cable, 3-wire
connection accessories	e.g. VK200075	e.g. VK200075	e.g. VK200075	-
mounting accessories (clip)	AY000046	AY000046	AY000046	AY000046

	top-series	top-series	preferential series	preferential series
article-no.	IB060173	IB0601A3	IM060100	IM060170
switching distance (Sn)	2.0mm	2.0mm	3.0mm	2.0mm
output signal	pnnp, no	pnnp, no	pnnp, no	pnnp, no
mounting	flush	flush	non-flush	non-flush
connection	M8-connector	cable	cable	M8-connector
article-no.	*	*	-	-
output signal	pnnp, nc	pnnp, nc	pnnp, nc	pnnp, nc
article-no.	*	*	-	-
output signal	nnpn, no	nnpn, no	nnpn, no	nnpn, no
article-no.	*	*	-	-
output signal	nnpn, nc	nnpn, nc	nnpn, nc	nnpn, nc
* on request				
TECHNICAL DATA				
switching distance (Sn)	2.0mm	2.0mm	3.0mm	2.0mm
output signal	see above	see above	see above	see above
operating voltage	10 ... 30V DC	10 ... 30V DC	10 ... 30V DC	10 ... 30V DC
current consumption (w/o load)	† 15mA	† 15mA	† 15mA	† 15mA
output current (max. load)	200mA	200mA	200mA	200mA
voltage drop (max. load)	2.0V DC	2.0V DC	2.0V DC	2.0V DC
Norm measuring plate	acc. to EN 60947-5-2	acc. to EN 60947-5-2	acc. to EN 60947-5-2	acc. to EN 60947-5-2
hysteresis	< 15%	< 15%	< 15%	< 15%
repeat accuracy	acc. to EN 60947-5-2	acc. to EN 60947-5-2	acc. to EN 60947-5-2	acc. to EN 60947-5-2
correction factor	see page 5	see page 5	see page 5	see page 5
switching frequency	1kHz	1kHz	1kHz	1kHz
display (signal)	yellow LED	yellow LED	yellow LED	yellow LED
short-circuit protection	+	+	+	+
reverse polarity protection	+	+	+	+
dimensions	Ø 6.5mm	Ø 6.5mm	Ø 6.5mm	Ø 6.5mm
length (thread/complete)	-/50mm	-/40mm	-/40mm	-/50mm
housing material	stainl. steel	stainl. steel	nickel-plated brass	nickel-plated brass
operating temperature	-25 ... +70°C	-25 ... +70°C	-25 ... +70°C	-25 ... +70°C
degree of protection (EN 60529)	IP67	IP67	IP67	IP67
connection	M8-connector, 3-pin	2m PUR cable, 3-wire	2m PUR cable, 3-wire	M8-connector, 3-pin
connection accessories	e.g. VK200075	-	-	e.g. VK200075
mounting accessories (clip)	AY000046	AY000046	AY000046	AY000046

	standard design	standard design	short design	short design
article-no.	IN060100	IN060170	IN060174	IN060104
switching distance (Sn)	3.0mm	3.0mm	3.0mm	3.0mm
output signal	pnp, no	pnp, no	pnp, no	pnp, no
mounting	non-flush	non-flush	non-flush	non-flush
connection	cable	M8-connector	M8-connector	cable
article-no.	*	IN060270	*	*
output signal	pnp, nc	pnp, nc	pnp, nc	pnp, nc
article-no.	*	IN061170	*	*
output signal	npn, no	npn, no	npn, no	npn, no
article-no.	*	*	*	*
output signal	npn, nc	npn, nc	npn, nc	npn, nc
* on request				
TECHNICAL DATA				
switching distance (Sn)	3.0mm	3.0mm	3.0mm	3.0mm
output signal	see above	see above	see above	see above
operating voltage	10 ... 30V DC	10 ... 30V DC	10 ... 30V DC	10 ... 30V DC
current consumption (w/o load)	† 15mA	† 15mA	† 15mA	† 15mA
output current (max. load)	200mA	200mA	200mA	200mA
voltage drop (max. load)	2.0V DC	2.0V DC	2.0V DC	2.0V DC
norm measuring plate	acc. to EN 60947-5-2	acc. to EN 60947-5-2	acc. to EN 60947-5-2	acc. to EN 60947-5-2
hysteresis	< 15%	< 15%	< 15%	< 15%
repeat accuracy	acc. to EN 60947-5-2	acc. to EN 60947-5-2	acc. to EN 60947-5-2	acc. to EN 60947-5-2
correction factor	see page 5	see page 5	see page 5	see page 5
switching frequency	1kHz	1kHz	1kHz	1kHz
display (signal)	yellow LED	yellow LED	yellow LED	yellow LED
short-circuit protection	+	+	+	+
reverse polarity protection	+	+	+	+
dimensions	Ø 6.5mm	Ø 6.5mm	Ø 6.5mm	Ø 6.5mm
length (thread/complete)	-/50mm	-/60mm	-/47mm	-/35.5mm
housing material	stainl. steel	stainl. steel	stainl. steel	stainl. steel
operating temperature	-25 ... +70°C	-25 ... +70°C	-25 ... +70°C	-25 ... +70°C
degree of protection (EN 60529)	IP67	IP67	IP67	IP67
connection	2m PUR cable, 3-wire	M8-connector, 3-pin	M8-connector, 3-pin	2m PUR cable, 3-wire
connection accessories	-	e.g. VK200075	e.g. VK200075	-
mounting accessories (clip)	AY000046	AY000046	AY000046	AY000046

	top-series	top-series		
article-no.	IN060173	IN0601A3		
switching distance (Sn)	4.0mm	4.0mm		
output signal	pnnp, no	pnnp, no		
mounting	non-flush	non-flush		
connection	M8-connector	cable		
article-no.	*	*		
output signal	pnnp, nc	pnnp, nc		
article-no.	*	*		
output signal	nnp, no	nnp, no		
article-no.	*	*		
output signal	nnp, nc	nnp, nc		
* on request				
TECHNICAL DATA				
switching distance (Sn)	4.0mm	4.0mm		
output signal	see above	see above		
operating voltage	10 ... 30V DC	10 ... 30V DC		
current consumption (w/o load)	† 15mA	† 15mA		
output current (max. load)	200mA	200mA		
voltage drop (max. load)	2.0V DC	2.0V DC		
norm measuring plate	acc. to EN 60947-5-2	acc. to EN 60947-5-2		
hysteresis	< 15%	< 15%		
repeat accuracy	acc. to EN 60947-5-2	acc. to EN 60947-5-2		
correction factor	see page 5	see page 5		
switching frequency	1kHz	1kHz		
display (signal)	yellow LED	yellow LED		
short-circuit protection	+	+		
reverse polarity protection	+	+		
dimensions	Ø 6.5mm	Ø 6.5mm		
length (thread/complete)	-/50mm	-/40mm		
housing material	stainl. steel	stainl. steel		
operating temperature	-25 ... +70°C	-25 ... +70°C		
degree of protection (EN 60529)	IP67	IP67		
connection	M8-connector, 3-pin	2m PUR cable, 3-wire		
connection accessories	e.g. VK200075	-		
mounting accessories (clip)	AY000046	AY000046		

	preferential series	preferential series	standard design	short design
article-no.	IA080100	IA080170	IB080100	IB080104
switching distance (Sn)	1.5mm	1.5mm	1.5mm	1.5mm
output signal	pnnp, no	pnnp, no	pnnp, no	pnnp, no
mounting	flush	flush	flush	flush
connection	cable	M8-connector	cable	cable
article-no.	-	-	IB080200	IB080204
output signal	pnnp, nc	pnnp, nc	pnnp, nc	pnnp, nc
article-no.	-	-	IB081100	IB081104
output signal	nnpn, no	nnpn, no	nnpn, no	nnpn, no
article-no.	-	-	*	*
output signal	nnpn, nc	nnpn, nc	nnpn, nc	nnpn, nc

* on request

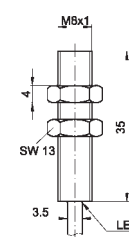
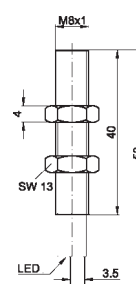
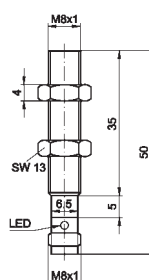
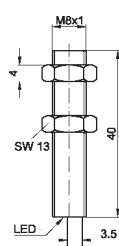

TECHNICAL DATA

switching distance (Sn)	1.5mm	1.5mm	1.5mm	1.5mm
output signal	see above	see above	see above	see above
operating voltage	10 ... 30V DC	10 ... 30V DC	10 ... 30V DC	10 ... 30V DC
current consumption (w/o load)	† 15mA	† 15mA	† 15mA	† 15mA
output current (max. load)	200mA	200mA	200mA	200mA
voltage drop (max. load)	2.0V DC	2.0V DC	2.0V DC	2.0V DC
norm measuring plate	acc. to EN 60947-5-2	acc. to EN 60947-5-2	acc. to EN 60947-5-2	acc. to EN 60947-5-2
hysteresis	< 15%	< 15%	< 15%	< 15%
repeat accuracy	acc. to EN 60947-5-2	acc. to EN 60947-5-2	acc. to EN 60947-5-2	acc. to EN 60947-5-2
correction factor	see page 5	see page 5	see page 5	see page 5
switching frequency	1kHz	1kHz	1kHz	1kHz
display (signal)	yellow LED	yellow LED	yellow LED	yellow LED
short-circuit protection	+	+	+	+
reverse polarity protection	+	+	+	+
dimensions	M8x1	M8x1	M8x1	M8x1
length (thread/complete)	40mm/40mm	35mm/50mm	40mm/50mm	35mm/35mm
housing material	nickel-plated brass	nickel-plated brass	stainl. steel	stainl. steel
operating temperature	-25 ... +70°C	-25 ... +70°C	-25 ... +70°C	-25 ... +70°C
degree of protection (EN 60529)	IP67	IP67	IP67	IP67
connection	2m PUR cable, 3-wire	M8-connector, 3-pin	2m PUR cable, 3-wire	2m PUR cable, 3-wire
connection accessories	-	e.g. VK200075	-	-
mounting accessories (universal holder)	AY000115	AY000115	AY000115	AY000115
mounting accessories (clip)	AY000047	AY000047	AY000047	AY000047

	standard design	standard design	short design	short design
article-no.	IB080121	IB080170	IB080174	IB080184
switching distance (Sn)	1.5mm	1.5mm	1.5mm	1.5mm
output signal	pnp, no	pnp, no	pnp, no	pnp, no
mounting	flush	flush	flush	flush
connection	M12-connector	M8-connector	M8-connector	M8-connector
article-no.	IB080221	IB080270	IB080274	IB080284
output signal	pnp, nc	pnp, nc	pnp, nc	pnp, nc
article-no.	IB081121	IB081170	IB081174	*
output signal	npn, no	npn, no	npn, no	npn, no
article-no.	*	*	*	*
output signal	npn, nc	npn, nc	npn, nc	npn, ncc
* on request				
TECHNICAL DATA				
switching distance (Sn)	1.5mm	1.5mm	1.5mm	1.5mm
output signal	see above	see above	see above	see above
operating voltage	10 ... 30V DC	10 ... 30V DC	10 ... 30V DC	10 ... 30V DC
current consumption (w/o load)	† 15mA	† 15mA	† 15mA	† 15mA
output current (max. load)	200mA	200mA	200mA	200mA
voltage drop (max. load)	2.0V DC	2.0V DC	2.0V DC	2.0V DC
norm measuring plate	acc. to EN 60947-5-2	acc. to EN 60947-5-2	acc. to EN 60947-5-2	acc. to EN 60947-5-2
hysteresis	< 15%	< 15%	< 15%	< 15%
repeat accuracy	acc. to EN 60947-5-2	acc. to EN 60947-5-2	acc. to EN 60947-5-2	acc. to EN 60947-5-2
correction factor	see page 5	see page 5	see page 5	see page 5
switching frequency	1kHz	1kHz	1kHz	1kHz
display (signal)	yellow LED	yellow LED	yellow LED	yellow LED
short-circuit protection	+	+	+	+
reverse polarity protection	+	+	+	+
dimensions	M8x1	M8x1	M8x1	M8x1
length (thread/complete)	39mm/60mm	45mm/60mm	31mm/45mm	20mm/29mm
housing material	stainl. steel	stainl. steel	nickel-plated brass	nickel-plated brass
operating temperature	-25 ... +70°C	-25 ... +70°C	-25 ... +70°C	-25 ... +70°C
degree of protection (EN 60529)	IP67	IP67	IP67	IP67
connection	M12-connector, 3-pin	M8-connector, 3-pin	M8-connector, 3-pin	M8-connector, 3-pin
connection accessories	e.g. VK200025	e.g. VK200075	e.g. VK200075	e.g. VK200075
mounting accessories (universal holder)	AY000115	AY000115	AY000115	AY000115
mounting accessories (clip)	AY000047	AY000047	AY000047	AY000047

	short design	top-series	top-series	top-series
article-no.	IB0801A4	IB080123	IB080173	IB0801A3
switching distance (Sn)	1.5mm	2.0mm	2.0mm	2.0mm
output signal	pnp, no	pnp, no	pnp, no	pnp, no
mounting	flush	flush	flush	flush
connection	cable	M12-connector	M8-connector	cable
article-no.	IB0802A4	*	IB080273	IB0802A3
output signal	pnp, nc	pnp, nc	pnp, nc	pnp, nc
article-no.	*	IB081123	*	IB0811A3
output signal	npn, no	npn, no	npn, no	npn, no
article-no.	*	*	*	*
output signal	npn, nc	npn, nc	npn, nc	npn, nc

* on request

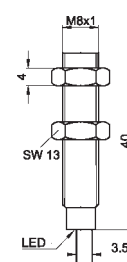
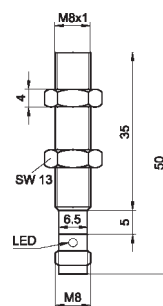
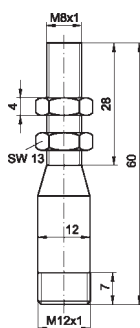
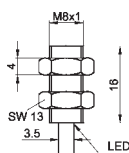

TECHNICAL DATA

switching distance (Sn)	1.5mm	2.0mm	2.0mm	2.0mm
output signal	see above	see above	see above	see above
operating voltage	10 ... 30V DC	10 ... 30V DC	10 ... 30V DC	10 ... 30V DC
current consumption (w/o load)	† 15mA	† 15mA	† 15mA	† 15mA
output current (max. load)	200mA	200mA	200mA	200mA
voltage drop (max. load)	2.0V DC	2.0V DC	2.0V DC	2.0V DC
norm measuring plate	acc. to EN 60947-5-2	acc. to EN 60947-5-2	acc. to EN 60947-5-2	acc. to EN 60947-5-2
hysteresis	< 15%	< 15%	< 15%	< 15%
repeat accuracy	acc. to EN 60947-5-2	acc. to EN 60947-5-2	acc. to EN 60947-5-2	acc. to EN 60947-5-2
correction factor	see page 5	see page 5	see page 5	see page 5
switching frequency	1kHz	1kHz	1kHz	1kHz
display (signal)	yellow LED	yellow LED	yellow LED	yellow LED
short-circuit protection	+	+	+	+
reverse polarity protection	+	+	+	+
dimensions	M8x1	M8x1	M8x1	M8x1
length (thread/complete)	16mm/16mm	28mm/60mm	35mm/50mm	35mm/40mm
housing material	stainl. steel	nickel-plated brass	stainl. steel	stainl. steel
operating temperature	-25 ... +70°C	-25 ... +70°C	-25 ... +70°C	-25 ... +70°C
degree of protection (EN 60529)	IP67	IP67	IP67	IP67
connection	2m PUR cable, 3-wire	M12-connector, 3-pin	M8-connector, 3-pin	2m PUR cable, 3-wire
connection accessories	-	e.g. VK200025	e.g. VK200075	-
mounting accessories (universal holder)	AY000115	AY000115	AY000115	AY000115
mounting accessories (clip)	AY000047	AY000047	AY000047	AY000047

	preferential series	preferential series	short design	short design
article-no.	IM080100	IM080170	IN080104	IN080174
switching distance (Sn)	2.0mm	2.0mm	2.5mm	2.5mm
output signal	pnnp, no	pnnp, no	pnnp, no	pnnp, no
mounting	non-flush	non-flush	non-flush	non-flush
connection	cable	M8-connector	cable	M8-connector
article-no.	-	-	*	*
output signal	pnnp, nc	pnnp, nc	pnnp, nc	pnnp, nc
article-no.	-	-	IN081104	IN081174
output signal	nnpn, no	nnpn, no	nnpn, no	nnpn, no
article-no.	-	-	*	*
output signal	nnpn, nc	nnpn, nc	nnpn, nc	nnpn, nc
* on request				
TECHNICAL DATA				
switching distance (Sn)	2.0mm	2.0mm	2.5mm	2.5mm
output signal	see above	see above	see above	see above
operating voltage	10 ... 30V DC	10 ... 30V DC	10 ... 30V DC	10 ... 30V DC
current consumption (w/o load)	† 15mA	† 15mA	† 15mA	† 15mA
output current (max. load)	200mA	200mA	200mA	200mA
voltage drop (max. load)	2.0V DC	2.0V DC	2.0V DC	2.0V DC
norm measuring plate	acc. to EN 60947-5-2	acc. to EN 60947-5-2	acc. to EN 60947-5-2	acc. to EN 60947-5-2
hysteresis	< 15%	< 15%	< 15%	< 15%
repeat accuracy	acc. to EN 60947-5-2	acc. to EN 60947-5-2	acc. to EN 60947-5-2	acc. to EN 60947-5-2
correction factor	see page 5	see page 5	see page 5	see page 5
switching frequency	1kHz	1kHz	1kHz	1kHz
display (signal)	yellow LED	yellow LED	yellow LED	yellow LED
short-circuit protection	+	+	+	+
reverse polarity protection	+	+	+	+
dimensions	M8x1	M8x1	M8x1	M8x1
length (thread/complete)	35mm/40mm	30mm/50mm	32mm/35mm	28mm/45mm
housing material	nickel-plated brass	nickel-plated brass	stainl. steel	nickel-plated brass
operating temperature	-25 ... +70°C	-25 ... +70°C	-25 ... +70°C	-25 ... +70°C
degree of protection (EN 60529)	IP67	IP67	IP67	IP67
connection	2m PUR cable, 3-wire	M8-connector, 3-pin	2m PUR cable, 3-wire	M8-connector, 3-pin
connection accessories	-	e.g. VK200075	-	e.g. VK200075
mounting accessories (universal holder)	AY000115	AY000115	AY000115	AY000115
mounting accessories (clip)	AY000047	AY000047	AY000047	AY000047

	standard design	standard design	standard design	top-series
article-no.	IN080100	IN080121	IN080170	IN080173
switching distance (Sn)	3mm	3mm	3mm	4mm
output signal	pnp, no	pnp, no	pnp, no	pnp, no
mounting	non-flush	non-flush	non-flush	non-flush
connection	cable	M12-connector	M8-connector	M8-connector
article-no.	IN080200	IN080221	IN080270	*
output signal	pnp, nc	pnp, nc	pnp, nc	pnp, nc
article-no.	*	*	*	IN081173
output signal	npn, no	npn, no	npn, no	npn, no
article-no.	*	*	IN081270	*
output signal	npn, nc	npn, nc	npn, nc	npn, nc

* on request

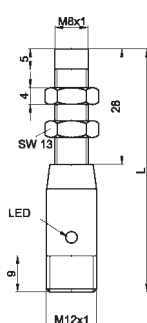
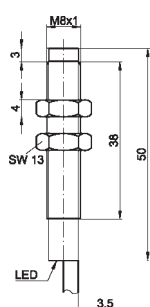

IN080121 L=60
IN080221 L=58

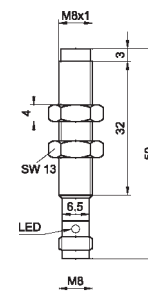
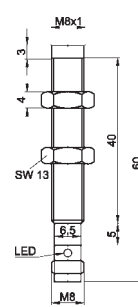

TECHNICAL DATA

switching distance (Sn)	3.0mm	3.0mm	3.0mm	4.0mm
output signal	see above	see above	see above	see above
operating voltage	10 ... 30V DC	10 ... 30V DC	10 ... 30V DC	10 ... 30V DC
current consumption (w/o load)	† 15mA	† 15mA	† 15mA	† 15mA
output current (max. load)	200mA	200mA	200mA	200mA
voltage drop (max. load)	2.0V DC	2.0V DC	2.0V DC	2.0V DC
norm measuring plate	acc. to EN 60947-5-2	acc. to EN 60947-5-2	acc. to EN 60947-5-2	acc. to EN 60947-5-2
hysteresis	< 15%	< 15%	< 15%	< 15%
repeat accuracy	acc. to EN 60947-5-2	acc. to EN 60947-5-2	acc. to EN 60947-5-2	acc. to EN 60947-5-2
correction factor	see page 5	see page 5	see page 5	see page 5
switching frequency	1kHz	1kHz	1kHz	1kHz
display (signal)	yellow LED	yellow LED	yellow LED	yellow LED
short-circuit protection	+	+	+	+
reverse polarity protection	+	+	+	+
dimensions	M8x1	M8x1	M8x1	M8x1
length (thread/complete)	38mm/50mm	23mm/s. oben	40mm/60mm	29mm/50mm
housing material	stainl. steel	nickel-plated brass	stainl. steel	stainl. steel
operating temperature	-25 ... +70°C	-25 ... +70°C	-25 ... +70°C	-25 ... +70°C
degree of protection (EN 60529)	IP67	IP67	IP67	IP67
connection	2m PUR cable, 3-wire	M12-connector, 3-pin	M8-connector, 3-pin	M8-connector, 3-pin
connection accessories	-	e.g. VK200025	e.g. VK200075	e.g. VK200075
mounting accessories (universal holder)	AY000115	AY000115	AY000115	AY000115
mounting accessories (clip)	AY000047	AY000047	AY000047	AY000047

	top-series			
article-no.	IN0801A3			
switching distance (Sn)	4mm			
output signal	pnp, no			
mounting	non-flush			
connection	cable			
article-no.	*			
output signal	pnp, nc			
article-no.	IN0811A3			
output signal	nnp, no			
article-no.	*			
output signal	nnp, nc			
* on request				
TECHNICAL DATA				
switching distance (Sn)	4.0mm			
output signal	see above			
operating voltage	10 ... 30V DC			
current consumption (w/o load)	† 15mA			
output current (max. load)	200mA			
voltage drop (max. load)	2.0V DC			
norm measuring plate	acc. to EN 60947-5-2			
hysteresis	< 15%			
repeat accuracy	acc. to EN 60947-5-2			
correction factor	see page 5			
switching frequency	1kHz			
display (signal)	yellow LED			
short-circuit protection	+			
reverse polarity protection	+			
dimensions	M8x1			
length (thread/complete)	31mm/40mm			
housing material	stainl. steel			
operating temperature	-25 ... +70°C			
degree of protection (EN 60529)	IP67			
connection	2m PUR cable, 3-wire			
connection accessories	-			
mounting accessories (universal holder)	AY000115			
mounting accessories (clip)	AY000047			

	preferential series	preferential series	preferential series	preferential series
article-no.	IA120100	IA120104	IA120120	IA120124
switching distance (Sn)	2mm	2mm	2mm	2mm
output signal	pnp, no	pnp, no	pnp, no	pnp, no
mounting	flush	flush	flush	flush
connection	cable	cable	M12-connector	M12-connector
article-no.	-	-	-	-
output signal	pnp, nc	pnp, nc	pnp, nc	pnp, nc
article-no.	-	-	-	-
output signal	npn, no	npn, no	npn, no	npn, no
article-no.	-	-	-	-
output signal	npn, nc	npn, nc	npn, nc	npn, nc
* on request				
TECHNICAL DATA				
switching distance (Sn)	2.0mm	2.0mm	2.0mm	2.0mm
output signal	see above	see above	see above	see above
operating voltage	10 ... 30V DC	10 ... 30V DC	10 ... 30V DC	10 ... 30V DC
current consumption (w/o load)	† 15mA	† 15mA	† 15mA	† 15mA
output current (max. load)	200mA	200mA	200mA	200mA
voltage drop (max. load)	2.0V DC	2.0V DC	2.0V DC	2.0V DC
norm measuring plate	acc. to EN 60947-5-2	acc. to EN 60947-5-2	acc. to EN 60947-5-2	acc. to EN 60947-5-2
hysteresis	< 15%	< 15%	< 15%	< 15%
repeat accuracy	acc. to EN 60947-5-2	acc. to EN 60947-5-2	acc. to EN 60947-5-2	acc. to EN 60947-5-2
correction factor	see page 5	see page 5	see page 5	see page 5
switching frequency	800Hz	800Hz	800Hz	800Hz
display (signal)	yellow LED	yellow LED	yellow LED	yellow LED
short-circuit protection	+	+	+	+
reverse polarity protection	+	+	+	+
dimensions	M12x1	M12x1	M12x1	M12x1
length (thread/complete)	38mm/50mm	30mm/30mm	40mm/60mm	23mm/45mm
housing material	nickel-plated brass	nickel-plated brass	nickel-plated brass	nickel-plated brass
operating temperature	-25 ... +70°C	-25 ... +70°C	-25 ... +70°C	-25 ... +70°C
degree of protection (EN 60529)	IP67	IP67	IP67	IP67
connection	2m PUR cable, 3-wire	2m PUR cable, 3-wire	M12-connector, 3-pin	M12-connector, 3-pin
connection accessories	-	-	e.g. VK200025	e.g. VK200025
mounting accessories (universal holder)	AY000115	AY000115	AY000115	AY000115
mounting accessories (clip)	AY000049	AY000049	AY000049	AY000049

	standard design	short design	standard design	short design
article-no.	IB120100	IB120104	IB120121	IB120125
switching distance (Sn)	3mm	3mm	3mm	3mm
output signal	pnp, no	pnp, no	pnp, no	pnp, no
mounting	flush	flush	flush	flush
connection	cable	cable	M12-connector	M12-connector
article-no.	IB120200	IB120204	IB120221	IB120225
output signal	pnp, nc	pnp, nc	pnp, nc	pnp, nc
article-no.	IB121100	*	IB121121	*
output signal	npn, no	npn, no	npn, no	npn, no
article-no.	IB121200	*	IB121221	*
output signal	npn, nc	npn, nc	npn, nc	npn, nc
* on request				
TECHNICAL DATA				
switching distance (Sn)	3.0mm	3.0mm	3.0mm	3.0mm
output signal	see above	see above	see above	see above
operating voltage	10 ... 30V DC	10 ... 30V DC	10 ... 30V DC	10 ... 30V DC
current consumption (w/o load)	† 15mA	† 15mA	† 15mA	† 15mA
output current (max. load)	200mA	200mA	200mA	200mA
voltage drop (max. load)	2.0V DC	2.0V DC	2.0V DC	2.0V DC
norm measuring plate	acc. to EN 60947-5-2	acc. to EN 60947-5-2	acc. to EN 60947-5-2	acc. to EN 60947-5-2
hysteresis	< 15%	< 15%	< 15%	< 15%
repeat accuracy	acc. to EN 60947-5-2	acc. to EN 60947-5-2	acc. to EN 60947-5-2	acc. to EN 60947-5-2
correction factor	see page 5	see page 5	see page 5	see page 5
switching frequency	800Hz	800Hz	800Hz	800Hz
display (signal)	yellow LED	yellow LED	yellow LED	yellow LED
short-circuit protection	+	+	+	+
reverse polarity protection	+	+	+	+
dimensions	M12x1	M12x1	M12x1	M12x1
length (thread/complete)	40mm/51.5mm	25mm/36mm	40mm/60mm	23mm/45mm
housing material	nickel-plated brass	nickel-plated brass	nickel-plated brass	nickel-plated brass
operating temperature	-25 ... +70°C	-25 ... +70°C	-25 ... +70°C	-25 ... +70°C
degree of protection (EN 60529)	IP67	IP67	IP67	IP67
connection	2m PUR cable, 3-wire	2m PUR cable, 3-wire	M12-connector, 3-pin	M12-connector, 3-pin
connection accessories	-	-	e.g. VK200025	e.g. VK200025
mounting accessories (universal holder)	AY000115	AY000115	AY000115	AY000115
mounting accessories (clip)	AY000049	AY000049	AY000049	AY000049

	standard design	short design	top-series	top-series
article-no.	IB120170	IB120174	IB120123	IB1201A3
switching distance (Sn)	3mm	3mm	4mm	4mm
output signal	pnp, no	pnp, no	pnp, no	pnp, no
mounting	flush	flush	flush	flush
connection	M8-connector	M8-connector	M12-connector	cable
article-no.	*	IB120274	IB120223	*
output signal	pnp, nc	pnp, nc	pnp, nc	pnp, nc
article-no.	IB121170	*	*	*
output signal	npn, no	npn, no	npn, no	npn, no
article-no.	*	*	*	*
output signal	npn, nc	npn, nc	npn, nc	npn, nc
* on request				
TECHNICAL DATA				
switching distance (Sn)	3.0mm	3.0mm	4.0mm	4.0mm
output signal	see above	see above	see above	see above
operating voltage	10 ... 30V DC	10 ... 30V DC	10 ... 30V DC	10 ... 30V DC
current consumption (w/o load)	† 15mA	† 15mA	† 15mA	† 15mA
output current (max. load)	200mA	200mA	200mA	200mA
voltage drop (max. load)	2.0V DC	2.0V DC	2.0V DC	2.0V DC
norm measuring plate	acc. to EN 60947-5-2	acc. to EN 60947-5-2	acc. to EN 60947-5-2	acc. to EN 60947-5-2
hysteresis	< 15%	< 15%	< 15%	< 15%
repeat accuracy	acc. to EN 60947-5-2	acc. to EN 60947-5-2	acc. to EN 60947-5-2	acc. to EN 60947-5-2
correction factor	see page 5	see page 5	see page 5	see page 5
switching frequency	800Hz	800Hz	800Hz	800Hz
display (signal)	yellow LED	yellow LED	yellow LED	yellow LED
short-circuit protection	+	+	+	+
reverse polarity protection	+	+	+	+
dimensions	M12x1	M12x1	M12x1	M12x1
length (thread/complete)	38.5m/60mm	24mm/44mm	40mm/60mm	38mm/50mm
housing material	stainl. steel	nickel-plated brass	nickel-plated brass	nickel-plated brass
operating temperature	-25 ... +70°C	-25 ... +70°C	-25 ... +70°C	-25 ... +70°C
degree of protection (EN 60529)	IP67	IP67	IP67	IP67
connection	M8-connector, 3-pin	M8-connector, 3-pin	M12-connector, 3-pin	2m PUR cable, 3-wire
connection accessories	e.g. VK200075	e.g. VK200075	e.g. VK200025	-
mounting accessories (universal holder)	AY000115	AY000115	AY000115	AY000115
mounting accessories (clip)	AY000049	AY000049	AY000049	AY000049

	preferential series	preferential series	preferential series	preferential series
article-no.	IM120100	IM120104	IM120120	IM120124
switching distance (Sn)	4mm	4mm	4mm	4mm
output signal	pnp, no	pnp, no	pnp, no	pnp, no
mounting	non-flush	non-flush	non-flush	non-flush
connection	cable	cable	M12-connector	M12-connector
article-no.	-	-	-	-
output signal	pnp, nc	pnp, nc	pnp, nc	pnp, nc
article-no.	-	-	-	-
output signal	npn, no	npn, no	npn, no	npn, no
article-no.	-	-	*	*
output signal	npn, nc	npn, nc	npn, nc	npn, nc
* on request				
TECHNICAL DATA				
switching distance (Sn)	4.0mm	4.0mm	4.0mm	4.0mm
output signal	see above	see above	see above	see above
operating voltage	10 ... 30V DC	10 ... 30V DC	10 ... 30V DC	10 ... 30V DC
current consumption (w/o load)	† 15mA	† 15mA	† 15mA	† 15mA
output current (max. load)	200mA	200mA	200mA	200mA
voltage drop (max. load)	2.0V DC	2.0V DC	2.0V DC	2.0V DC
norm measuring plate	acc. to EN 60947-5-2	acc. to EN 60947-5-2	acc. to EN 60947-5-2	acc. to EN 60947-5-2
hysteresis	< 15%	< 15%	< 15%	< 15%
repeat accuracy	acc. to EN 60947-5-2	acc. to EN 60947-5-2	acc. to EN 60947-5-2	acc. to EN 60947-5-2
correction factor	see page 5	see page 5	see page 5	see page 5
switching frequency	400Hz	400Hz	400Hz	400Hz
display (signal)	yellow LED	yellow LED	yellow LED	yellow LED
short-circuit protection	+	+	+	+
reverse polarity protection	+	+	+	+
dimensions	M12x1	M12x1	M12x1	M12x1
length (thread/complete)	33mm/50mm	31mm/37mm	34mm/60mm	18mm/45mm
housing material	nickel-plated brass	nickel-plated brass	nickel-plated brass	nickel-plated brass
operating temperature	-25 ... +70°C	-25 ... +70°C	-25 ... +70°C	-25 ... +70°C
degree of protection (EN 60529)	IP67	IP67	IP67	IP67
connection	2m PUR cable, 3-wire	2m PUR cable, 3-wire	M12-connector, 3-pin	M12-connector, 3-pin
connection accessories	-	-	e.g. VK200025	e.g. VK200025
mounting accessories (universal holder)	AY000115	AY000115	AY000115	AY000115
mounting accessories (clip)	AY000049	AY000049	AY000049	AY000049

	standard design	short design	standard design	short design
article-no.	IN120100	IN120104	IN120121	IN120125
switching distance (Sn)	6.0mm	6.0mm	6.0mm	6.0mm
output signal	pnp, no	pnp, no	pnp, no	pnp, no
mounting	non-flush	non-flush	non-flush	non-flush
connection	cable	cable	M12-connector	M12-connector
article-no.	IN120200	IN120204	IN120221	IN120225
output signal	pnp, nc	pnp, nc	pnp, nc	pnp, nc
article-no.	IN121100	IN121104	IN121121	*
output signal	npn, no	npn, no	npn, no	npn, no
article-no.	*	*	IN121221	*
output signal	npn, nc	npn, nc	npn, nc	npn, nc

* on request

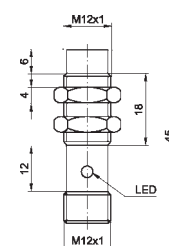
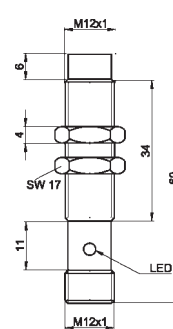
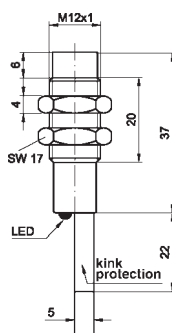
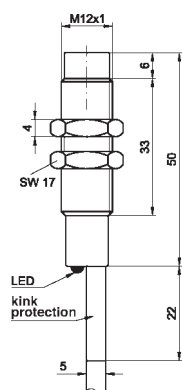

TECHNICAL DATA

switching distance (Sn)	6.0mm	6.0mm	6.0mm	6.0mm
output signal	see above	see above	see above	see above
operating voltage	10 ... 30V DC	10 ... 30V DC	10 ... 30V DC	10 ... 30V DC
current consumption (w/o load)	† 15mA	† 15mA	† 15mA	† 15mA
output current (max. load)	200mA	200mA	200mA	200mA
voltage drop (max. load)	2.0V DC	2.0V DC	2.0V DC	2.0V DC
norm measuring plate	acc. to EN 60947-5-2	acc. to EN 60947-5-2	acc. to EN 60947-5-2	acc. to EN 60947-5-2
hysteresis	< 15%	< 15%	< 15%	< 15%
repeat accuracy	acc. to EN 60947-5-2	acc. to EN 60947-5-2	acc. to EN 60947-5-2	acc. to EN 60947-5-2
correction factor	see page 5	see page 5	see page 5	see page 5
switching frequency	400Hz	400Hz	400Hz	400Hz
display (signal)	yellow LED	yellow LED	yellow LED	yellow LED
short-circuit protection	+	+	+	+
reverse polarity protection	+	+	+	+
dimensions	M12x1	M12x1	M12x1	M12x1
length (thread/complete)	33mm/50mm	20mm/37mm	34mm/60mm	18mm/45mm
housing material	nickel-plated brass	nickel-plated brass	nickel-plated brass	nickel-plated brass
operating temperature	-25 ... +70°C	-25 ... +70°C	-25 ... +70°C	-25 ... +70°C
degree of protection (EN 60529)	IP67	IP67	IP67	IP67
connection	2m PUR cable, 3-wire	2m PUR cable, 3-wire	M12-connector, 3-pin	M12-connector, 3-pin
connection accessories	-	-	e.g. VK200025	e.g. VK200025
mounting accessories (universal holder)	AY000115	AY000115	AY000115	AY000115
mounting accessories (clip)	AY000049	AY000049	AY000049	AY000049

	standard design	short design	top-series	top-series
article-no.	IN120170	IN120174	IN120123	IN1201A3
switching distance (Sn)	6.0mm	6.0mm	8.0mm	8.0mm
output signal	pnnp, no	pnnp, no	pnnp, no	pnnp, no
mounting	non-flush	non-flush	non-flush	non-flush
connection	M8-connector	M8-connector	M12-connector	cable
article-no.	*	IN120274	*	IN1202A3
output signal	pnnp, nc	pnnp, nc	pnnp, nc	pnnp, nc
article-no.	IN121170	*	*	*
output signal	nnpn, no	nnpn, no	nnpn, no	nnpn, no
article-no.	*	*	*	*
output signal	nnpn, nc	nnpn, nc	nnpn, nc	nnpn, nc
* on request				
TECHNICAL DATA				
switching distance (Sn)	6.0mm	6.0mm	8.0mm	8.0mm
output signal	see above	see above	see above	see above
operating voltage	10 ... 30V DC	10 ... 30V DC	10 ... 30V DC	10 ... 30V DC
current consumption (w/o load)	† 15mA	† 15mA	† 15mA	† 15mA
output current (max. load)	200mA	200mA	200mA	200mA
voltage drop (max. load)	2.0V DC	2.0V DC	2.0V DC	2.0V DC
norm measuring plate	acc. to EN 60947-5-2	acc. to EN 60947-5-2	acc. to EN 60947-5-2	acc. to EN 60947-5-2
hysteresis	< 15%	< 15%	< 15%	< 15%
repeat accuracy	acc. to EN 60947-5-2	acc. to EN 60947-5-2	acc. to EN 60947-5-2	acc. to EN 60947-5-2
correction factor	see page 5	see page 5	see page 5	see page 5
switching frequency	400Hz	400Hz	400Hz	400Hz
display (signal)	yellow LED	yellow LED	yellow LED	yellow LED
short-circuit protection	+	+	+	+
reverse polarity protection	+	+	+	+
dimensions	M12x1	M12x1	M12x1	M12x1
length (thread/complete)	33mm/60mm	18mm/35mm	34mm/60mm	33mm/50mm
housing material	nickel-plated brass	nickel-plated brass	stainl. steel	stainl. steel
operating temperature	-25 ... +70°C	-25 ... +70°C	-25 ... +70°C	-25 ... +70°C
degree of protection (EN 60529)	IP67	IP67	IP67	IP67
connection	M8-connector, 3-pin	M8-connector, 3-pin	M12-connector, 3-pin	2m PUR cable, 3-wire
connection accessories	e.g. VK200075	e.g. VK200075	e.g. VK200025	-
mounting accessories (universal holder)	AY000115	AY000115	AY000115	AY000115
mounting accessories (clip)	AY000049	AY000049	AY000049	AY000049

	standard design	standard design	standard design	standard design
article-no.	IB125100	IB125130	IN125100	IN125130
switching distance (Sn)	2mm	2mm	4mm	4mm
output signal	AC, no	AC, no	AC, no	AC, no
mounting	flush	flush	non-flush	non-flush
connection	cable	MC connector	cable	MC connector
article-no.	-	-	IN125200	IN125230
output signal	-	-	AC, nc	AC, nc
* on request				
TECHNICAL DATA				
switching distance (Sn)	2.0mm	2.0mm	4.0mm	4.0mm
output signal	AC, no	AC, no	see above	see above
operating voltage	20 ... 250V AC/DC	20 ... 250V AC/DC	20 ... 250V AC/DC	20 ... 250V AC/DC
current consumption (w/o load)	† 15mA	† 15mA	† 15mA	† 15mA
output current (max. load)	300mA	300mA	180mA	300mA
voltage drop (max. load)	5.0V AC	5.0V AC	5.0V AC	5.0V AC
norm measuring plate	acc. to EN 60947-5-2	acc. to EN 60947-5-2	acc. to EN 60947-5-2	acc. to EN 60947-5-2
hysteresis	< 15%	< 15%	< 15%	< 15%
repeat accuracy	acc. to EN 60947-5-2	acc. to EN 60947-5-2	acc. to EN 60947-5-2	acc. to EN 60947-5-2
correction factor	see page 5	see page 5	see page 5	see page 5
switching frequency	30Hz	30Hz	30Hz	30Hz
display (signal)	yellow LED	yellow LED	yellow LED	yellow LED
short-circuit protection	+	+	+	+
reverse polarity protection	-	-	-	-
dimensions	M12x1	M12x1	M12x1	M12x1
length (thread/complete)	59mm/70mm	45mm/75mm	40mm/66.5mm	54mm/80mm
housing material	nickel-plated brass	nickel-plated brass	nickel-plated brass	nickel-plated brass
operating temperature	-25 ... +70°C	-25 ... +70°C	-25 ... +70°C	-25 ... +70°C
degree of protection (EN 60529)	IP67	IP67	IP67	IP67
connection	2m PVC-cable, 3-wire	MC-connector, 3-pin	2m PVC-cable, 3-wire	MC-connector, 3-pin
connection accessories	-	e.g. VK201034	-	e.g. VK201034
mounting accessories (universal holder)	AY000115	AY000115	AY000115	AY000115
mounting accessories (clip)	AY000049	AY000049	AY000049	AY000049

	standard design	short design	standard design	short design
article-no.	IA180100	IA180120	IB180100	IB180104
switching distance (Sn)	5.0mm	5.0mm	5.0mm	5.0mm
output signal	pnp, no	pnp, no	pnp, no	pnp, no
mounting	flush	flush	flush	flush
connection	cable	M12-connector	cable	cable
article-no.	-	-	IB180200	*
output signal	pnp, nc	pnp, nc	pnp, nc	pnp, nc
article-no.	-	-	IB181100	*
output signal	npn, no	npn, no	npn, no	npn, no
article-no.	-	-	*	*
output signal	npn, nc	npn, nc	npn, nc	npn, nc
* on request				
TECHNICAL DATA				
switching distance (Sn)	5.0mm	5.0mm	5.0mm	5.0mm
output signal	see above	see above	see above	see above
operating voltage	10 ... 30V DC	10 ... 30V DC	10 ... 30V DC	10 ... 30V DC
current consumption (w/o load)	† 15mA	† 15mA	† 15mA	† 15mA
output current (max. load)	200mA	200mA	200mA	200mA
voltage drop (max. load)	2.0V DC	2.0V DC	2.0V DC	2.0V DC
norm measuring plate	acc. to EN 60947-5-2	acc. to EN 60947-5-2	acc. to EN 60947-5-2	acc. to EN 60947-5-2
hysteresis	< 15%	< 15%	< 15%	< 15%
repeat accuracy	acc. to EN 60947-5-2	acc. to EN 60947-5-2	acc. to EN 60947-5-2	acc. to EN 60947-5-2
correction factor	see page 5	see page 5	see page 5	see page 5
switching frequency	500Hz	500Hz	500Hz	500Hz
display (signal)	yellow LED	yellow LED	yellow LED	yellow LED
short-circuit protection	+	+	+	+
reverse polarity protection	+	+	+	+
dimensions	M18x1	M18x1	M18x1	M18x1
length (thread/complete)	40mm/50mm	45mm/62mm	50mm/62mm	30mm/41mm
housing material	nickel-plated brass	nickel-plated brass	nickel-plated brass	nickel-plated brass
operating temperature	-25 ... +70°C	-25 ... +70°C	-25 ... +70°C	-25 ... +70°C
degree of protection (EN 60529)	IP67	IP67	IP67	IP67
connection	2m PUR cable, 3-wire	M12-connector, 3-pin	2m PUR cable, 3-wire	2m PUR cable, 3-wire
connection accessories	-	e.g. VK200025	-	-
mounting accessories (universal holder)	AY000117	AY000117	AY000117	AY000117
mounting accessories (clip)	AY000051	AY000051	AY000051	AY000051

	standard design	short design	top-series	top-series
article-no.	IB180121	IB180125	IB180123	IB1801A3
switching distance (Sn)	5.0mm	5.0mm	7.0mm	7.0mm
output signal	pnp, no	pnp, no	pnp, no	pnp, no
mounting	flush	flush	flush	flush
connection	M12-connector	M12-connector	M12-connector	cable
article-no.	IB180221	IB180225	IB180223	*
output signal	pnp, nc	pnp, nc	pnp, nc	pnp, nc
article-no.	IB181121	-	*	*
output signal	npn, no	npn, no	npn, no	npn, no
article-no.	IB181221	-	*	*
output signal	npn, nc	npn, nc	npn, nc	npn, nc

* on request

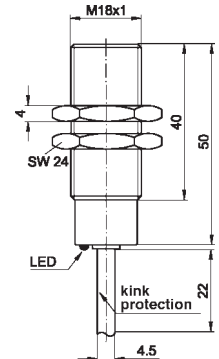
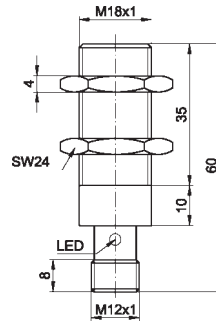
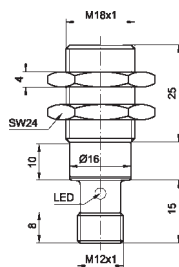
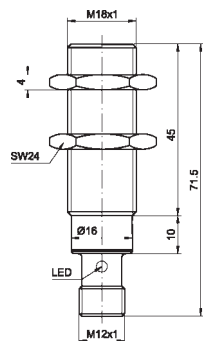

TECHNICAL DATA

switching distance (Sn)	5.0mm	5.0mm	7.0mm	7.0mm
output signal	see above	see above	see above	see above
operating voltage	10 ... 30V DC	10 ... 30V DC	10 ... 30V DC	10 ... 30V DC
current consumption (w/o load)	† 15mA	† 15mA	† 15mA	† 15mA
output current (max. load)	200mA	200mA	200mA	200mA
voltage drop (max. load)	2.0V DC	2.0V DC	2.0V DC	2.0V DC
norm measuring plate	acc. to EN 60947-5-2	acc. to EN 60947-5-2	acc. to EN 60947-5-2	acc. to EN 60947-5-2
hysteresis	< 15%	< 15%	< 15%	< 15%
repeat accuracy	acc. to EN 60947-5-2	acc. to EN 60947-5-2	acc. to EN 60947-5-2	acc. to EN 60947-5-2
correction factor	see page 5	see page 5	see page 5	see page 5
switching frequency	500Hz	500Hz	500Hz	500Hz
display (signal)	yellow LED	yellow LED	yellow LED	yellow LED
short-circuit protection	+	+	+	+
reverse polarity protection	+	+	+	+
dimensions	M18x1	M18x1	M18x1	M18x1
length (thread/complete)	45mm/71.5mm	25mm/50mm	35mm/60mm	40mm/50mm
housing material	nickel-plated brass	nickel-plated brass	stainl. steel	stainl. steel
operating temperature	-25 ... +70°C	-25 ... +70°C	-25 ... +70°C	-25 ... +70°C
degree of protection (EN 60529)	IP67	IP67	IP67	IP67
connection	M12-connector, 3-pin	M12-connector, 3-pin	M12-connector, 3-pin	2m PUR cable, 3-wire
connection accessories	e.g. VK200025	e.g. VK200025	e.g. VK200025	-
mounting accessories (universal holder)	AY000117	AY000117	AY000117	AY000117
mounting accessories (clip)	AY000051	AY000051	AY000051	AY000051

	preferential series	preferential series	standard design	short design
article-no.	IM180100	IM180120	IN180100	IN180104
switching distance (Sn)	8.0mm	8.0mm	8.0mm	8.0mm
output signal	pnnp, no	pnnp, no	pnnp, no	pnnp, no
mounting	non-flush	non-flush	non-flush	non-flush
connection	cable	M12-connector	cable	cable
article-no.	-	-	*	IN180204
output signal	pnnp, nc	pnnp, nc	pnnp, nc	pnnp, nc
article-no.	-	-	IN181100	*
output signal	nnpn, no	nnpn, no	nnpn, no	nnpn, no
article-no.	-	-	*	*
output signal	nnpn, nc	nnpn, nc	nnpn, nc	nnpn, nc
* on request				
TECHNICAL DATA				
switching distance (Sn)	7.0mm	7.0mm	8.0mm	8.0mm
output signal	see above	see above	see above	see above
operating voltage	10 ... 30V DC	10 ... 30V DC	10 ... 30V DC	10 ... 30V DC
current consumption (w/o load)	† 15mA	† 15mA	† 15mA	† 15mA
output current (max. load)	200mA	200mA	200mA	200mA
voltage drop (max. load)	2.0V DC	2.0V DC	2.0V DC	2.0V DC
norm measuring plate	acc. to EN 60947-5-2	acc. to EN 60947-5-2	acc. to EN 60947-5-2	acc. to EN 60947-5-2
hysteresis	< 15%	< 15%	< 15%	< 15%
repeat accuracy	acc. to EN 60947-5-2	acc. to EN 60947-5-2	acc. to EN 60947-5-2	acc. to EN 60947-5-2
correction factor	see page 5	see page 5	see page 5	see page 5
switching frequency	200Hz	200Hz	200Hz	200Hz
display (signal)	yellow LED	yellow LED	yellow LED	yellow LED
short-circuit protection	+	+	+	+
reverse polarity protection	+	+	+	+
dimensions	M18x1	M18x1	M18x1	M18x1
length (thread/complete)	30mm/50mm	35mm/70mm	40mm/61mm	20mm/41mm
housing material	nickel-plated brass	nickel-plated brass	nickel-plated brass	nickel-plated brass
operating temperature	-25 ... +70°C	-25 ... +70°C	-25 ... +70°C	-25 ... +70°C
degree of protection (EN 60529)	IP67	IP67	IP67	IP67
connection	2m PUR cable, 3-wire	M12-connector, 3-pin	2m PUR cable, 3-wire	2m PUR cable, 3-wire
connection accessories	-	e.g. VK200025	-	-
mounting accessories (universal holder)	AY000117	AY000117	AY000117	AY000117
mounting accessories (clip)	AY000051	AY000051	AY000051	AY000051

	standard design	short design	top-series	top-series
article-no.	IN180121	IN180125	IN180123	IN1801A3
switching distance (Sn)	10.0mm	10.0mm	12.0mm	12.0mm
output signal	pnp, no	pnp, no	pnp, no	pnp, no
mounting	non-flush	non-flush	non-flush	non-flush
connection	M12-connector	M12-connector	M12-connector	cable
article-no.	IN180221	IN180225	*	*
output signal	pnp, nc	pnp, nc	pnp, nc	pnp, nc
article-no.	IN181121	*	*	*
output signal	npn, no	npn, no	npn, no	npn, no
article-no.	*	*	*	*
output signal	npn, nc	npn, nc	npn, nc	npn, nc

* on request

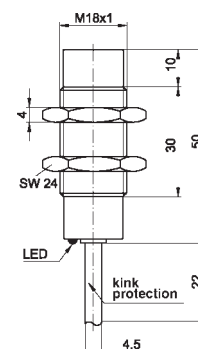
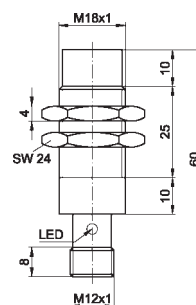
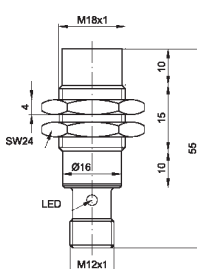
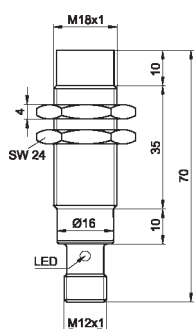

TECHNICAL DATA

switching distance (Sn)	10.0mm	10.0mm	12.0mm	12.0mm
output signal	see above	see above	see above	see above
operating voltage	10 ... 30V DC	10 ... 30V DC	10 ... 30V DC	10 ... 30V DC
current consumption (w/o load)	† 15mA	† 15mA	† 15mA	† 15mA
output current (max. load)	200mA	200mA	200mA	200mA
voltage drop (max. load)	2.0V DC	2.0V DC	2.0V DC	2.0V DC
norm measuring plate	acc. to EN 60947-5-2	acc. to EN 60947-5-2	acc. to EN 60947-5-2	acc. to EN 60947-5-2
hysteresis	< 15%	< 15%	< 15%	< 15%
repeat accuracy	acc. to EN 60947-5-2	acc. to EN 60947-5-2	acc. to EN 60947-5-2	acc. to EN 60947-5-2
correction factor	see page 5	see page 5	see page 5	see page 5
switching frequency	200Hz	200Hz	200Hz	200Hz
display (signal)	yellow LED	yellow LED	yellow LED	yellow LED
short-circuit protection	+	+	+	+
reverse polarity protection	+	+	+	+
dimensions	M18x1	M18x1	M18x1	M18x1
length (thread/complete)	35mm/70mm	15mm/50mm	25mm/60mm	30mm/50mm
housing material	nickel-plated brass	nickel-plated brass	stainl. steel	stainl. steel
operating temperature	-25 ... +70°C	-25 ... +70°C	-25 ... +70°C	-25 ... +70°C
degree of protection (EN 60529)	IP67	IP67	IP67	IP67
connection	M12-connector, 3-pin	M12-connector, 3-pin	M12-connector, 3-pin	2m PUR cable, 3-wire
connection accessories	e.g. VK200025	e.g. VK200025	e.g. VK200025	-
mounting accessories (universal holder)	AY000117	AY000117	AY000117	AY000117
mounting accessories (clip)	AY000051	AY000051	AY000051	AY000051

	standard design	standard design	standard design	standard design
article-no.	IB185100	IB185130	IN185100	IN185130
switching distance (Sn)	5.0mm	5.0mm	8.0mm	8.0mm
output signal	AC, no	AC, no	AC, no	AC, no
mounting	flush	flush	non-flush	non-flush
connection	cable	MC connector	cable	MC connector
article-no.	IB185200	IB185230	IN185200	IN185230
output signal	AC, nc	AC, nc	AC, nc	AC, nc
* on request				
TECHNICAL DATA				
switching distance (Sn)	5.0mm	5.0mm	8.0mm	8.0mm
output signal	see above	see above	see above	see above
operating voltage	20 ... 250V AC/DC	20 ... 250V AC/DC	20 ... 250V AC/DC	20 ... 250V AC/DC
current consumption (w/o load)	† 15mA	† 15mA	† 15mA	† 15mA
output current (max. load)	350mA	350mA	350mA	350mA
voltage drop (max. load)	5.0V AC	5.0V AC	5.0V AC	5.0V AC
norm measuring plate	acc. to EN 60947-5-2	acc. to EN 60947-5-2	acc. to EN 60947-5-2	acc. to EN 60947-5-2
hysteresis	< 15%	< 15%	< 15%	< 15%
repeat accuracy	acc. to EN 60947-5-2	acc. to EN 60947-5-2	acc. to EN 60947-5-2	acc. to EN 60947-5-2
correction factor	see page 5	see page 5	see page 5	see page 5
switching frequency	30Hz	30Hz	30Hz	30Hz
display (signal)	yellow LED	yellow LED	yellow LED	yellow LED
short-circuit protection	+	+	+	+
reverse polarity protection	-	-	-	-
dimensions	M18x1	M18x1	M18x1	M18x1
length (thread/complete)	50mm/60mm	54mm/80mm	41mm/60mm	44mm/80mm
housing material	nickel-plated brass	nickel-plated brass	nickel-plated brass	nickel-plated brass
operating temperature	-25 ... +70°C	-25 ... +70°C	-25 ... +70°C	-25 ... +70°C
degree of protection (EN 60529)	IP67	IP67	IP67	IP67
connection	2m PVC-cable, 2-wire	MC-connector, 3-pin	2m PVC-cable, 2-wire	MC-connector, 3-pin
connection accessories	-	e.g. VK201034	-	e.g. VK201034
mounting accessories (universal holder)	AY000117	AY000117	AY000117	AY000117
mounting accessories (clip)	AY000051	AY000051	AY000051	AY000051

	preferential series	preferential series	standard design	standard design
article-no.	IA300100	IA300120	IB300100	IB300121
switching distance (Sn)	10mm	10mm	10mm	10mm
output signal	pnp, no	pnp, no	pnp, no	pnp, no
mounting	flush	flush	flush	flush
connection	cable	M12-connector	cable	M12-connector
article-no.	-	-	*	*
output signal	pnp, nc	pnp, nc	pnp, nc	pnp, nc
article-no.	-	-	IB301100	*
output signal	npn, no	npn, no	npn, no	npn, no
article-no.	-	-	*	*
output signal	npn, nc	npn, nc	npn, nc	npn, nc
* on request				
TECHNICAL DATA				
switching distance (Sn)	10.0mm	10.0mm	10.0mm	10.0mm
output signal	see above	see above	see above	see above
operating voltage	10 ... 30V DC	10 ... 30V DC	10 ... 30V DC	10 ... 30V DC
current consumption (w/o load)	† 15mA	† 15mA	† 15mA	† 15mA
output current (max. load)	200mA	200mA	200mA	200mA
voltage drop (max. load)	2.0V DC	2.0V DC	2.0V DC	2.0V DC
norm measuring plate	acc. to EN 60947-5-2	acc. to EN 60947-5-2	acc. to EN 60947-5-2	acc. to EN 60947-5-2
hysteresis	< 15%	< 15%	< 15%	< 15%
repeat accuracy	acc. to EN 60947-5-2	acc. to EN 60947-5-2	acc. to EN 60947-5-2	acc. to EN 60947-5-2
correction factor	see page 5	see page 5	see page 5	see page 5
switching frequency	300Hz	300Hz	300Hz	300Hz
display (signal)	yellow LED	yellow LED	yellow LED	yellow LED
short-circuit protection	+	+	+	+
reverse polarity protection	+	+	+	+
dimensions	M30x1.5	M30x1.5	M30x1.5	M30x1.5
length (thread/complete)	51mm/60mm	44mm/70mm	51mm/60mm	44mm/70mm
housing material	nickel-plated brass	nickel-plated brass	nickel-plated brass	nickel-plated brass
operating temperature	-25 ... +70°C	-25 ... +70°C	-25 ... +70°C	-25 ... +70°C
degree of protection (EN 60529)	IP67	IP67	IP67	IP67
connection	2m PUR cable, 3-wire	M12-connector, 3-pin	2m PUR cable, 3-wire	M12-Sttecker, 3-pin
connection accessories	-	e.g. VK200025	-	e.g. VK200025
mounting accessories (clip)	AY000061	AY000061	AY000061	AY000061

	top-series	top-series	preferential series	preferential series
article-no.	IB300123	IB3001A3	IM300100	IM300120
switching distance (Sn)	15mm	15mm	15mm	15mm
output signal	pnnp, no	pnnp, no	pnnp, no	pnnp, no
mounting	flush	flush	non-flush	non-flush
connection	M12-connector	cable	cable	M12-connector
article-no.	*	*	-	-
output signal	pnnp, nc	pnnp, nc	pnnp, nc	pnnp, nc
article-no.	*	*	-	-
output signal	nnpn, no	nnpn, no	nnpn, no	nnpn, no
article-no.	*	*	-	-
output signal	nnpn, nc	nnpn, nc	nnpn, nc	nnpn, nc
* on request				
TECHNICAL DATA				
switching distance (Sn)	15.0mm	15.0mm	15.0mm	15.0mm
output signal	see above	see above	see above	see above
operating voltage	10 ... 30V DC	10 ... 30V DC	10 ... 30V DC	10 ... 30V DC
current consumption (w/o load)	† 15mA	† 15mA	† 15mA	† 15mA
output current (max. load)	200mA	200mA	200mA	200mA
voltage drop (max. load)	2.0V DC	2.0V DC	2.0V DC	2.0V DC
norm measuring plate	acc. to EN 60947-5-2	acc. to EN 60947-5-2	acc. to EN 60947-5-2	acc. to EN 60947-5-2
hysteresis	< 15%	< 15%	< 15%	< 15%
repeat accuracy	acc. to EN 60947-5-2	acc. to EN 60947-5-2	acc. to EN 60947-5-2	acc. to EN 60947-5-2
correction factor	see page 5	see page 5	see page 5	see page 5
switching frequency	300Hz	300Hz	100Hz	100Hz
display (signal)	yellow LED	yellow LED	yellow LED	yellow LED
short-circuit protection	+	+	+	+
reverse polarity protection	+	+	+	+
dimensions	M30x1.5	M30x1.5	M30x1.5	M30x1.5
length (thread/complete)	44mm/70mm	51mm/60mm	35mm/60mm	30mm/70mm
housing material	stainl. steel	stainl. steel	nickel-plated brass	nickel-plated brass
operating temperature	-25 ... +70°C	-25 ... +70°C	-25 ... +70°C	-25 ... +70°C
degree of protection (EN 60529)	IP67	IP67	IP67	IP67
connection	M12-connector, 3-pin	2m PUR cable, 3-wire	2m PUR cable, 3-wire	M12-connector, 3-pin
connection accessories	e.g. VK200025	-	-	e.g. VK200025
mounting accessories (clip)	AY000061	AY000061	AY000061	AY000061

article-no.	standard design IN300100	standard design IN300121	top-series IN300123	top-series IN3001A3
switching distance (Sn)	20mm	20mm	20mm	20mm
output signal	pnp, no	pnp, no	pnp, no	pnp, no
mounting	non-flush	non-flush	non-flush	non-flush
connection	cable	M12-connector	M12-connector	cable
article-no.	IN300200	IN300221	*	*
output signal	pnp, nc	pnp, nc	pnp, nc	pnp, nc
article-no.	*	*	*	*
output signal	npn, no	npn, no	npn, no	npn, no
article-no.	*	*	*	*
output signal	npn, nc	npn, nc	npn, nc	npn, nc

* on request

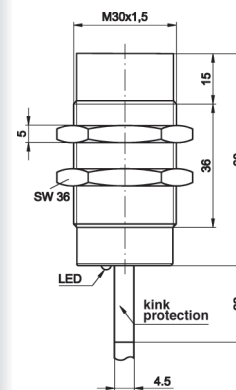
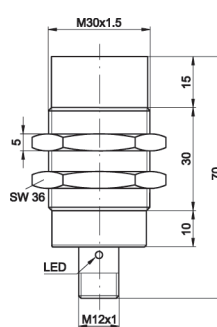
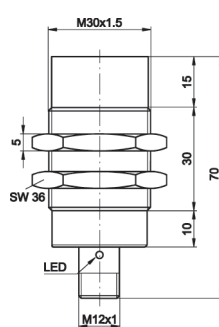
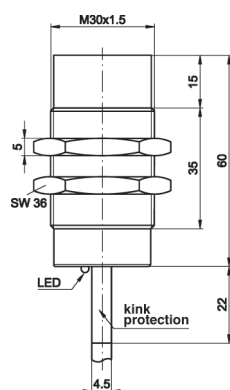

TECHNICAL DATA

switching distance (Sn)	20.0mm	20.0mm	20.0mm	20.0mm
output signal	see above	see above	see above	see above
operating voltage	10 ... 30V DC	10 ... 30V DC	10 ... 30V DC	10 ... 30V DC
current consumption (w/o load)	† 15mA	† 15mA	† 15mA	† 15mA
output current (max. load)	200mA	200mA	200mA	200mA
voltage drop (max. load)	2.0V DC	2.0V DC	2.0V DC	2.0V DC
norm measuring plate	acc. to EN 60947-5-2	acc. to EN 60947-5-2	acc. to EN 60947-5-2	acc. to EN 60947-5-2
hysteresis	< 15%	< 15%	< 15%	< 15%
repeat accuracy	acc. to EN 60947-5-2	acc. to EN 60947-5-2	acc. to EN 60947-5-2	acc. to EN 60947-5-2
correction factor	see page 5	see page 5	see page 5	see page 5
switching frequency	100Hz	100Hz	100Hz	100Hz
display (signal)	yellow LED	yellow LED	yellow LED	yellow LED
short-circuit protection	+	+	+	+
reverse polarity protection	+	+	+	+
dimensions	M30x1.5	M30x1.5	M30x1.5	M30x1.5
length (thread/complete)	35mm/60mm	30mm/70mm	30mm/70mm	36mm/60mm
housing material	nickel-plated brass	nickel-plated brass	stainl. steel	stainl. steel
operating temperature	-25 ... +70°C	-25 ... +70°C	-25 ... +70°C	-25 ... +70°C
degree of protection (EN 60529)	IP67	IP67	IP67	IP67
connection	2m PUR cable, 3-wire	M12-connector, 3-pin	M12-connector, 3-pin	2m PUR cable, 3-wire
connection accessories	-	e.g. VK200025	e.g. VK200025	-
mounting accessories (clip)	AY000061	AY000061	AY000061	AY000061

	standard design	standard design	standard design	standard design
article-no.	IB305100	IB305130	IN305100	IN305130
switching distance (Sn)	10mm	10mm	15mm	15mm
output signal	AC, no	AC, no	AC, no	AC, no
mounting	flush	flush	non-flush	non-flush
connection	cable	MC connector	cable	MC connector
article-no.	IB305200	IB305230	IN305200	IN305230
output signal	AC, nc	AC, nc	AC, nc	AC, nc
* on request				
TECHNICAL DATA				
switching distance (Sn)	10.0mm	10.0mm	15.0mm	15.0mm
output signal	see above	see above	see above	see above
operating voltage	20 ... 250V AC/DC	20 ... 250V AC/DC	20 ... 250V AC/DC	20 ... 250V AC/DC
current consumption (w/o load)	† 15mA	† 15mA	† 15mA	† 15mA
output current (max. load)	350mA	350mA	350mA	350mA
voltage drop (max. load)	5.0V AC	5.0V AC	5.0V AC	5.0V AC
norm measuring plate	acc. to EN 60947-5-2	acc. to EN 60947-5-2	acc. to EN 60947-5-2	acc. to EN 60947-5-2
hysteresis	< 15%	< 15%	< 15%	< 15%
repeat accuracy	acc. to EN 60947-5-2	acc. to EN 60947-5-2	acc. to EN 60947-5-2	acc. to EN 60947-5-2
correction factor	see page 5	see page 5	see page 5	see page 5
switching frequency	30Hz	30Hz	30Hz	35Hz
display (signal)	yellow LED	yellow LED	yellow LED	yellow LED
short-circuit protection	+	+	+	+
reverse polarity protection	-	-	-	-
dimensions	M30x1.5	M30x1.5	M30x1.5	M30x1.5
length (thread/complete)	60mm/82mm	60mm/89mm	50mm/81mm	37mm/80mm
housing material	nickel-plated brass	nickel-plated brass	nickel-plated brass	nickel-plated brass
operating temperature	-25 ... +70°C	-25 ... +70°C	-25 ... +70°C	-25 ... +70°C
degree of protection (EN 60529)	IP67	IP67	IP67	IP67
connection	2m PVC-cable, 2-wire	MC-connector, 3-pin	2m PVC-cable, 2-wire	MC-connector, 3-pin
connection accessories	-	e.g. VK201034	-	e.g. VK201034
mounting accessories (clip)	AY000061	AY000061	AY000061	AY000061

connection

3-pin PNP, no

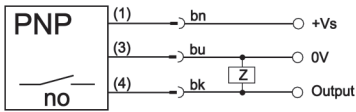

3-pin PNP, nc

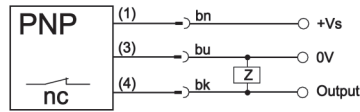

3-pin NPN, no

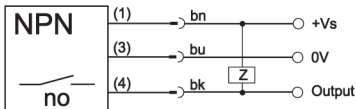

3-pin NPN, nc

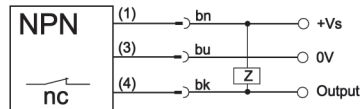

wire colors: bn = brown (1), bu = blue (3), bk = black (4)

For devices with M12-connector and normally closed contact function (nc), the switching output is wired via PIN2. For this reason a 4-wire cable socket should be used and the connection made via the white wire.

3-pin, PNP, nc, M12-connector

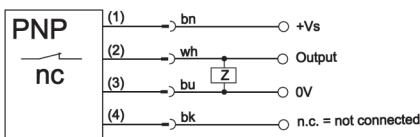

3-pin, NPN, nc, M12-connector

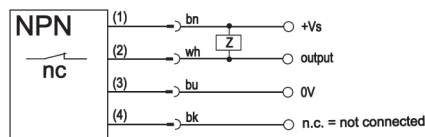

wire colors: bn = brown (1), wh = white (2), bu = blue (3)

2-pin, AC/DC, no

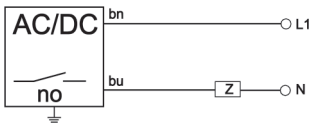

2-pin, AC/DC, nc

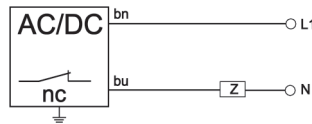

wire colors: bn = brown (1), bu = blue (2)

3-pin, AC/DC, MC-connector, no



3-pin, AC/DC, MC-connector, nc



wire colors: gn = green (1), rd/bk = red/black (2), rd/wh = red/white (3)

norm switching distances 1100

cable socket: number of pins (assigned):	M8, angular 3-pin	M8, straight 3-pin	M12, angular 3-pin
article-no. length	VK200071 2m	VK200075 2m	VK200021 2m
article-no. length	VK500071 5m	VK500075 5m	VK500021 5m
article-no. length	VKA00071 10m	VKA00075 10m	VKA0002 10m
cable socket: number of pins (assigned):	M12, straight 3-pin	MC, angular 3-pin	MC, straight 3-pin
article-no. length	VK200025 2m	VK201030 2m	VK201034 2m
article-no. length	VK500025 5m	- -	- -
article-no. length	VKA00025 10m	- -	- -

mounting material / quick clips

fig. 1

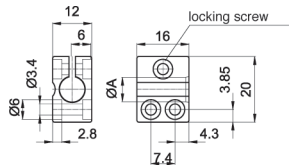

dimension A = sensor diameter

fig. 2

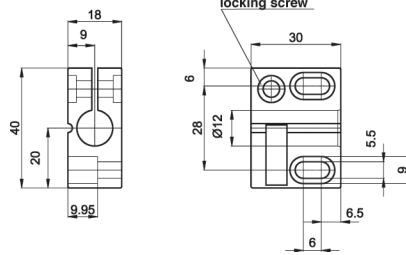

fig. 3

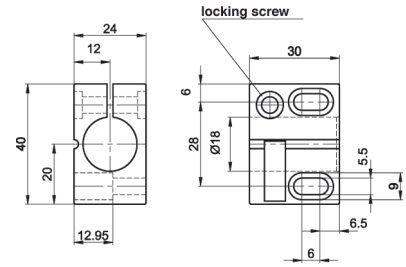

fig. 4

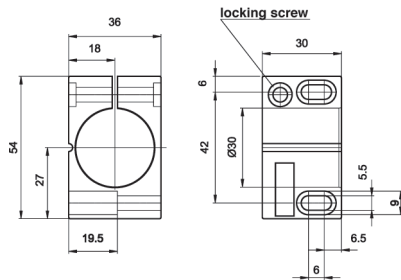

fig. 5

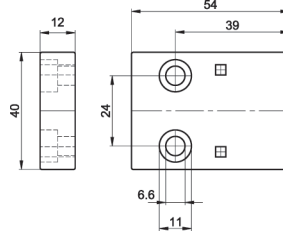
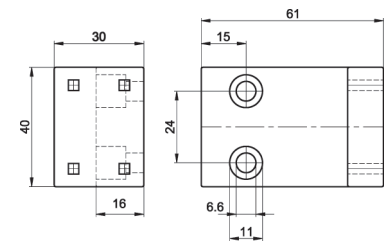

fig. 6



example



ACCESSORIES

article-no.	description	dimensions	fig.
AY000044	quick clip 4, plastic	sensor 4round, mounting clip	1
AY000045	quick clip 5, plastic	sensor 5round, mounting clip	1
AY000046	quick clip 6.5, plastic	sensor 6.5round, mounting clip	1
AY000047	quick clip 8, plastic	sensor 8round, mounting clip	1
AY000048	quick clip 8, plastic	sensor 8round, mounting clip, positive stop	1
AY000049	quick clip 12, plastic	sensor 12round, mounting clip	2
AY000050	quick clip 12, plastic	sensor 12round, mounting clip, positive stop	2
AY000051	quick clip 18, plastic	sensor 18round, mounting clip	3
AY000052	quick clip 18, plastic	sensor 18round, mounting clip, positive stop	3
AY000061	quick clip 30, plastic	sensor 30round, mounting clip	4
AY000062	quick clip 30, plastic	sensor 30round, mounting clip, positive stop	4
AY000053	base, straight, plastic	for quick clip 12 + 18round	5
AY000054	base, angular, plastic	for quick clip 12 + 18round	6
AY000055	label, white	for quick clip 12 + 18 + 30round	without

universal mounting AY000115 consisting of base module ...

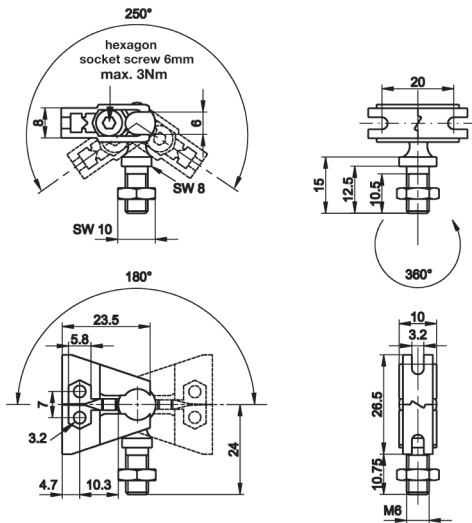

... and fitting panel

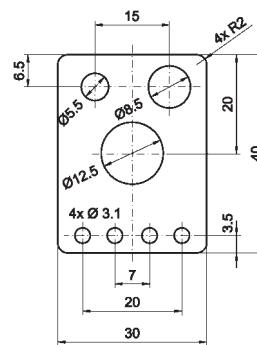

universal mounting AY000117 consisting of base module ...

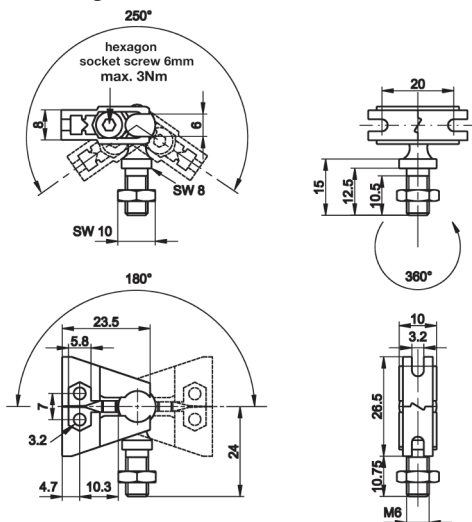

... and fitting panel

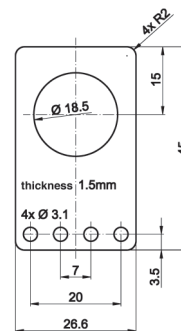

ACCESSORIES

article-no.	description	note
AY000088	base module *	flanges: stainless steel, ball pins: galvanized steel
AY000115	mounting kit for M5, M8, M12 sensors	stainless steel
AY000117	mounting kit for M18 sensors	stainless steel

* The AY000088 base module is contained in every mounting kit.

Material of bolts and nuts: galvanized steel



ipf electronic gmbh

Kalver Straße 25 – 27
58515 Lüdenscheid

Tel +49 2351 9365-0
Fax +49 2351 9365-19

www.ipf-electronic.com
info@ipf-electronic.com

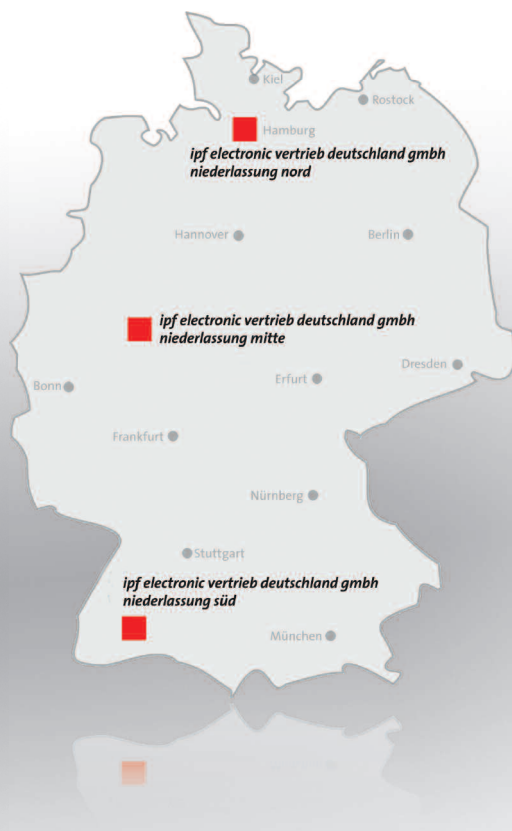

Germany

ipf electronic vertrieb deutschland gmbh – niederlassung nord

Kirchenstraße 16
21224 Rosengarten

Tel +49 4108 4189-0
Fax +49 4108 4189-19

nord@ipf.de

ipf electronic vertrieb deutschland gmbh – niederlassung mitte

Römerweg 25
58513 Lüdenscheid

Tel +49 2351 41032
Fax +49 2351 45131

mitte@ipf.de

ipf ipf electronic vertrieb deutschland gmbh – niederlassung süd

Flöschgasse 41
78647 Trossingen

Tel +49 7425 94005-0
Fax +49 7425 94005-5

sued@ipf.de

World-wide

ipf electronic gmbh – export division

Kalver Straße 25 – 27
58515 Lüdenscheid

Tel +49 2351 98597-0
Fax +49 2351 98597-29

export@ipf-electronic.com

